



LS Adjustable Engine Mount Installation

www.totalcostinvolved.com

Tech Line: 1-855-693-1259

**CHECK ALL PARTS INCLUDED IN THIS KIT TO THE PARTS LIST BEFORE INSTALLATION.
IF ANY PIECES ARE MISSING, PLEASE CONTACT: TOTAL COST INVOLVED 1-855-693-1259**

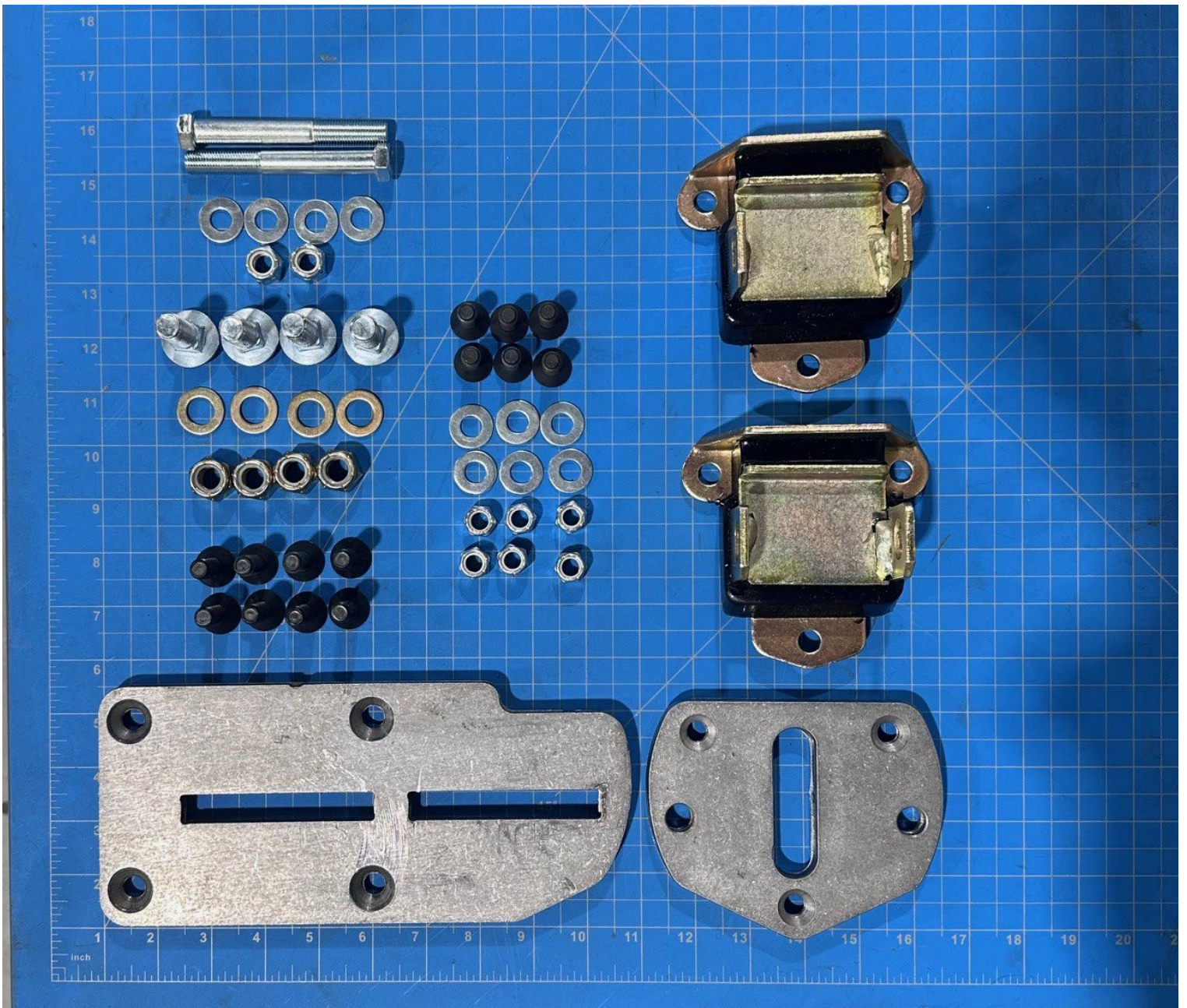

Parts list

Part Number	Description	Quantity
LS_ADJ_PLT_REG_MNT	ADJUSTABLE LS BLOCK PLATE REG	2
LS_ADJ_PLT_POLY_MNT	ADJUSTABLE LS POLY MOUNT PLT	2
700-7131-00	POLYURETHANE ENGINE MTR MT	2
1/2 BOLT 36	1/2-13 x 1 1/4 SQR-NK CARRIAGE	4
1/2 WASHER 04	1/2" AN960 WASHER	4
1/2 NUT 09	1/2-13 NYLOC G8	4
7/16 BOLT 02	7/16-20 X 3.1/2 BOLT GR 5 PLTD	2
7/16 WASHER 02	7/16 W SAE PLTD	4
7/16 NUT 03	7/16-20 NUT LK NY JAM PLTD	2
3/8 BOLT 18	3/8-24 X 1" SOC CAP FLAT	6
3/8 WASHER 01	3/8 FLAT WASHER	6
3/8 NUT 01	3/8-24 NUT LK NY PLTD	6
10MM BOLT 02	M10-1.5 X 30MM SOC CAP FLAT	8

The installation steps are as follows:

- Use the three 3/8-24 x 1" countersunk bolts, flat washers and Nylock nuts to attach engine mounts to the smaller of the two plates. These plates are the same left and right.

Note: Do not use the T shaped backing plates behind the motor mounts.

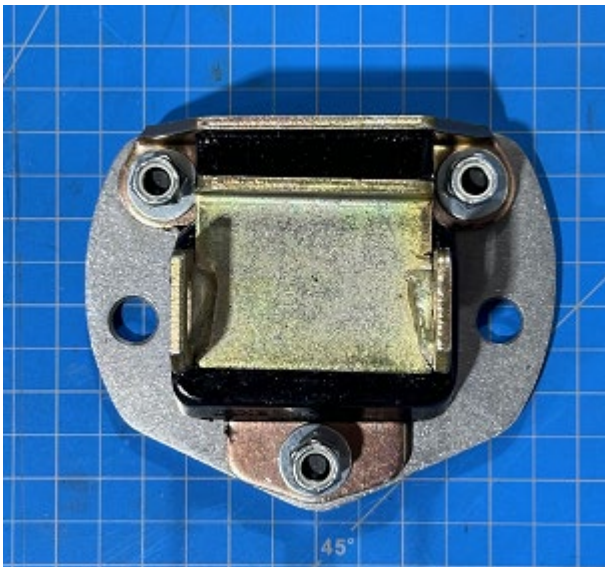

- Insert the two 1/2-13 x 1 1/4 carriage bolts into the block adapter plates and attach the plates to the block with the eight 10mm-1.5 x 30mm countersunk bolts. **Note: Passenger's side shown. Driver's side is a mirror image.**

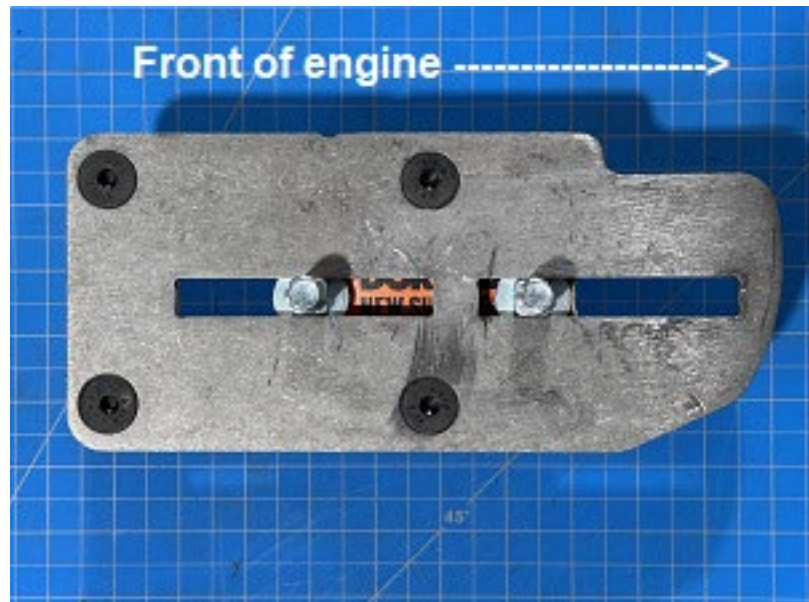

-Attach the engine mount plates to the block adapter plates using the two 1/2" AN flat washers and 1/2"-13 Nylock nuts. Do not tighten at this time.

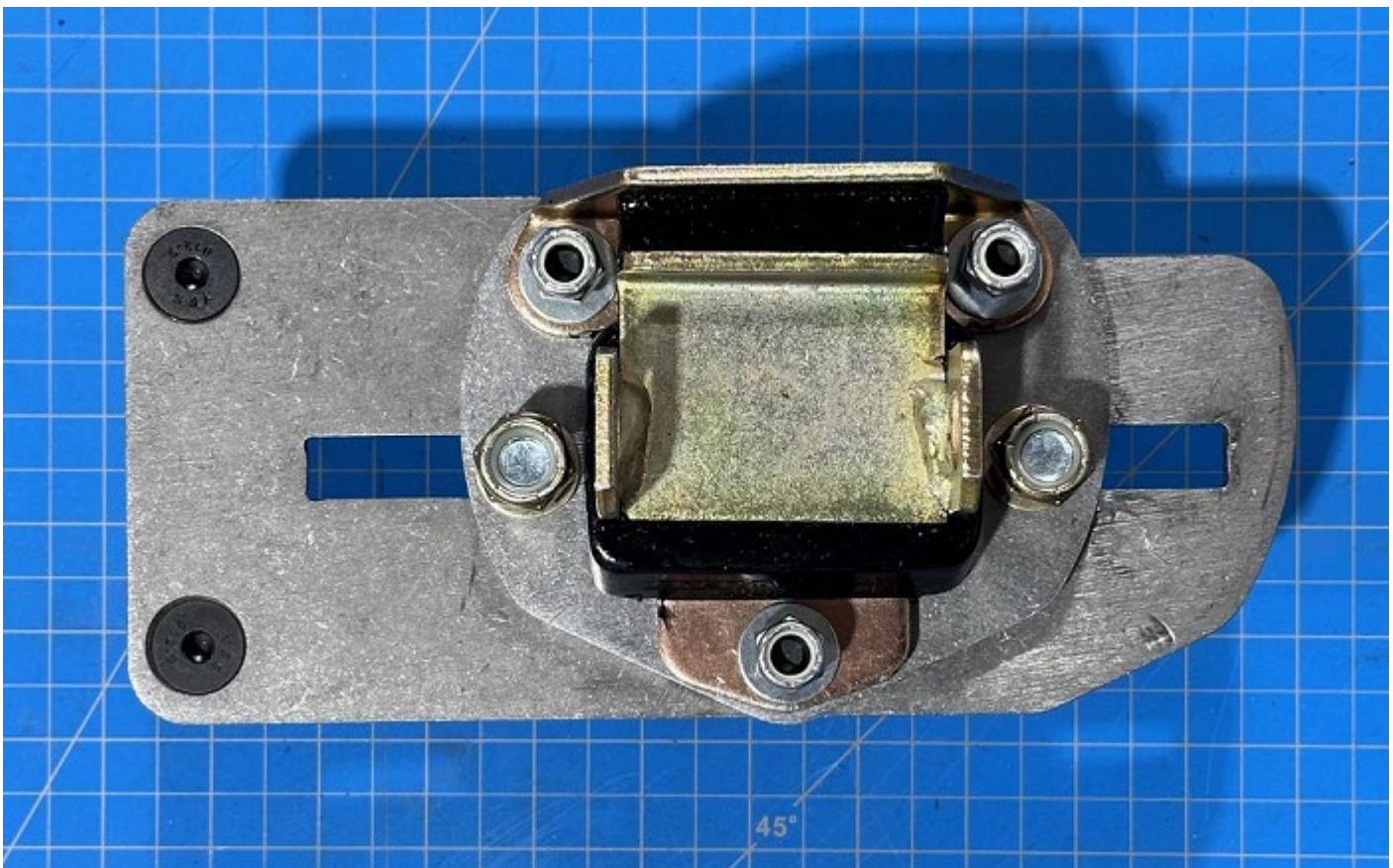

Here is the completed assembly on the passenger side.
Set the engine in place, adjust the fore/aft position as needed. When the engine position is correct, tighten the two 1/2" x 13 Nylock nuts on each side. Attach the engine to the chassis using the two 7/16"- 20 x 3.5" bolts, four 7/16 flat washers and two 7/16-20 Nylock nuts.

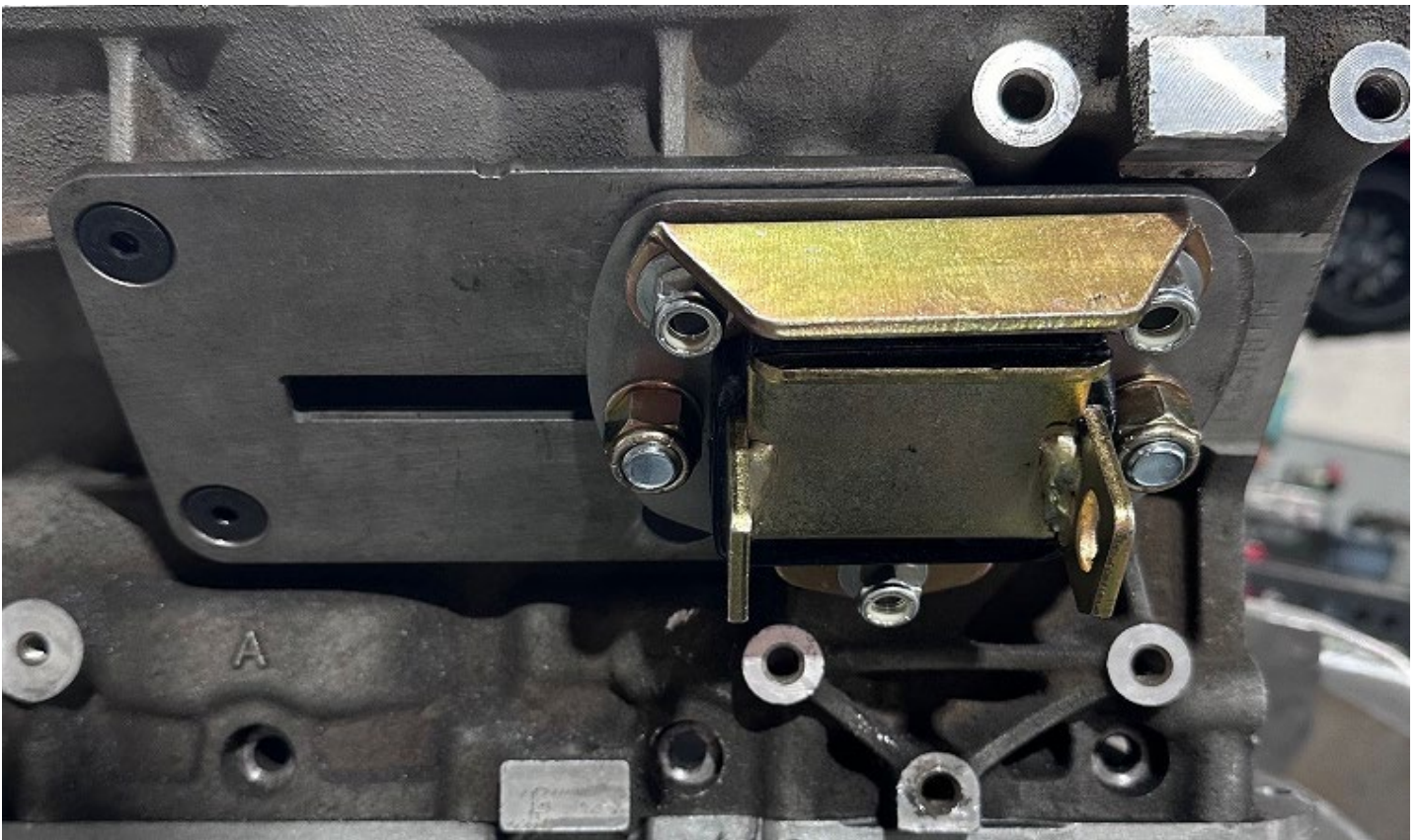

Thank you again for using Total Cost Involved products!

