



1960-1965 Falcon and '62-65 Comet & Ranchero Coil Spring IFS Installation Manual

Tech line: 1-855-693-1259
www.totalcostinvolved.com

Read and understand these instructions before starting any work!

**USE THE PARTS LIST BELOW TO MAKE SURE YOUR KIT IS COMPLETE BEFORE INSTALLATION.
 IF ANY PIECES ARE MISSING, PLEASE CONTACT: Total Cost Involved Engineering 855-693-1259**

All engine installations with this front end will require a rear sump oil pan.

The following Ford Racing Oil Pans will work.

289-302 Ford Racing # M-6675-A50 and the 351W: M-6675-A58

1960-1965 Falcon or '62-65 Comet & Ranchero - Coil-Spring Front End Parts List – Part#: * 227-2352-0cp-b0q-1bh or 227-2352-0am-aaq-6ah – The asterisk shown is the plain and standard package	
1 Coil-Spring Cross member	1 Rack & Pinion Bolt Kit – Hardware
• * Part #: 227-2356-00	• Power Rack Part #: 300-3235-00
2 Plain Upper Control Arms – Hardware	• Manual Part #: 300-3231-00
• * Part #: 200-2257-00 – Plain	1 Tie Rod Ends Set – Hardware
• Part #: 200-2257-01 – Black	• Part #: 301-3236-00
• Part #: 200-2257-02 – Polished	2 Assembled: Drop Spindle w/11” Rotors and Calipers BP: 4.5 Part# * spasyspa11dag-gmn
2 Plain Lower Control Arms – Hardware	2 Sway Bar and Mount – Hardware 3/8 Bolt Kit
• * Part #: 227-2557-00 – Coil-Spring - Plain	Part #: swaybar-f15-pln or chrome
• Part #: 227-2557-02 – Coil-Spring - Black	• Part #: swy-bar-heims12 mod - 1/2 Modified Heims:
• Part #: 227-2557-05 – Coil-Spring - Polished	• Part #: swy_bar_bolt-10-pln
1 Rack & Pinion – Only	2 Shocks Painted Body - Part#: skbdy03-0
• Power Rack Part #: 304-3215-00	2 Sway Bar and Mount – Hardware 3/8 Bolt Kit
• Manual Rack Part #: 304-3205-00	2 Coil-Springs - Black Powder Coated - Part#: Coil over springs 600lbs yellow dot or regular coil springs 300lbs green dot flat end of spring
1 Strut Rod Ends – Plain for M2 Rack& Pinion Unit	• Part #: swy_bar_mnt_05-pln or pol
• Part#: 301-3236-00	2 Falcon Inner Panels with hardware – Part#: 927-9962-00

~ Coil-Spring Front End ~

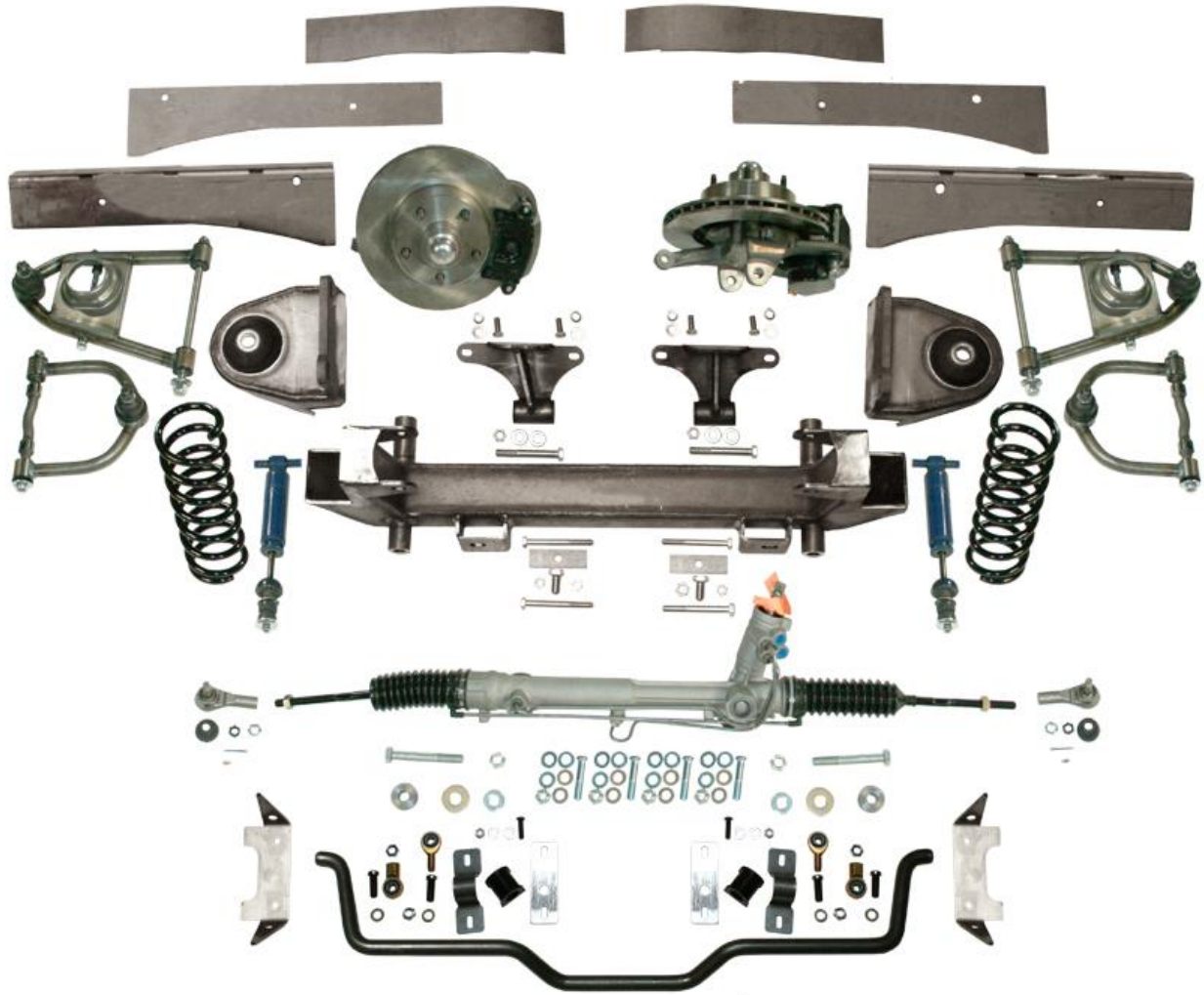

Front Suspension Installation Instructions

Thank you for choosing TCI Engineering's Falcon front suspension package. The kit has been designed to not only allow your vehicle to handle corners, steer, and brake better and have more engine compartment room but also have that low sports car stance. Although the install will require some cutting, grinding, drilling, welding and some manual labor, the results are well worth the effort.

BEFORE



AFTER





The engine has to be removed. On this project, we decided to leave the transmission installed just to see if it hampered the front end installation. It did not so you can also leave it in place just make sure to hold the bell housing in place with something strong.



Remove all the old suspension components including the steering column. I used a die grinder with a cut off wheel to cut the coils in a couple of places for much easier removal.



Remove the lower A-arm/motor mount brackets. When cutting, be careful not to cut into the main frame rail. We will be grinding off the excess material on the main rail.



Next item that needs to be removed are the shock towers. The first cut will be made from inside the wheel well just above the main frame rail flange.

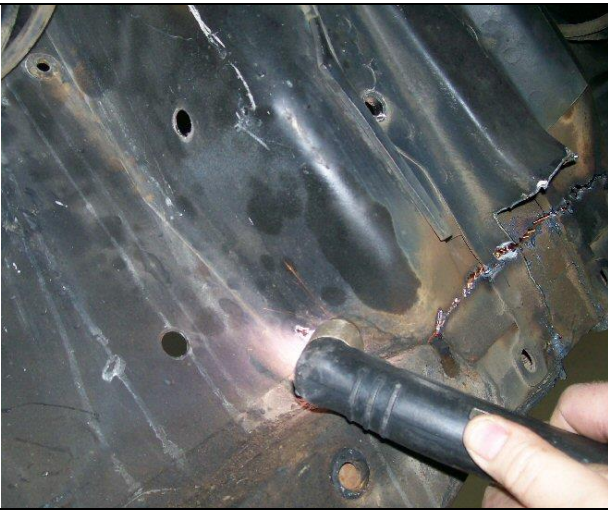

The rest of the cutting will be from inside the engine compartment.

Cut the lower edges of the tower from the frame rail.



The vertical cuts on the towers are made at the bend radius between the tower and fender panel.



The final cut is made across the top in the bend radius.



The TCI anti-sway bar package requires the stock sway bar brackets and the strut rod support channels to also be removed.



Remove all excess material, welds, and paint from the main rails to allow for the installation of the boxing plates.

Remove excess material around the shock tower opening until it is flat to the new fender panel; Also: Clean up the cut lines on the inside for a cleaner appearance.



The outer flange on the top of the main rail has to be removed.

Draw a line through the centers of the spot welds.



Carefully cut the flange off, leave about 1/8" or so extra material sticking up.

Use a grinder to remove the last 1/8" material.

If you try to plasma cut the entire flange off in one pass you will remove too much material from the frame rail.

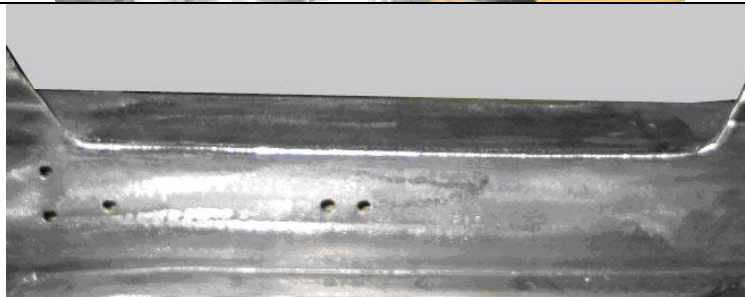

Finish grinding the rest of the remaining flange lip flat with to the top of the rail.

Although you cannot see it in the picture, there is a split between the top and the side rail metal.

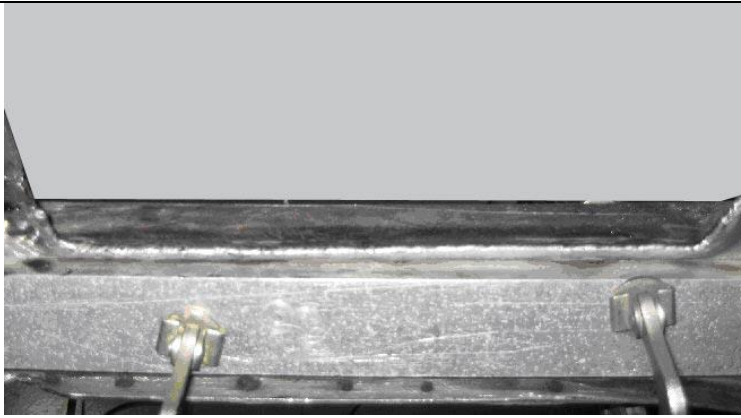

The top and outside of the rail need to be seam welded back together.

We made a quick little welding guide fixture so we could weld the seam as straight as possible. We clamped a two foot flat piece of material (I used 1" x 2" aluminum bar) about 3/4" down from the top of the frame rail to maintain a straight edge. Then we just laid the welding tip onto the top of the bar and used it as a guide.

Massage down any high spots or irregularities that aren't straight or square with a small hammer. Finally, weld the seam and side together making sure the seam attaches both pieces of material.

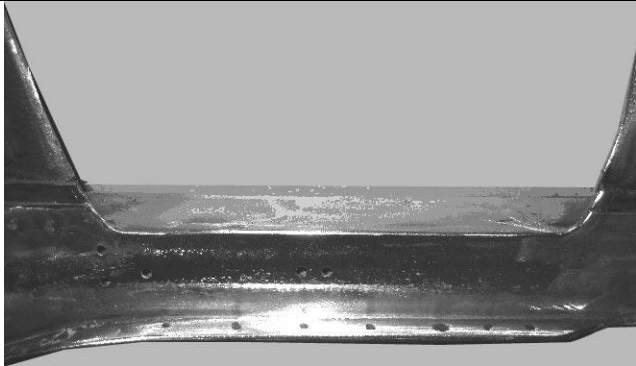

Grind the welded area flat and square.

At this point, you are done are done preparing the frame rails.

This is a good time to do any other engine compartment cleaning you would like.



You are now ready to start installing the boxing plates to strengthen the frame in the cross member area.

The folded inside boxing plates are located by using a bolt. Align the rear hole in the folded bracket with the existing hole on the frame rail (drivers side 7/16" x 3" bolt) and the upper idler arm hole (passenger side 3/8" x 3" bolt).

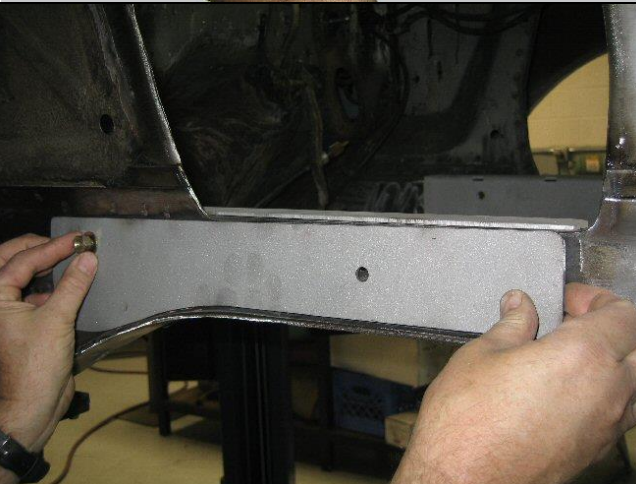

Install the correct outside boxing plate with the bolt and fasten with nut. (The plate with the hole closest to the rear edge of the plate is the passenger side.)

Align the boxing plate edge parallel with the top plate exposing an even section of the stock frame that when welded will tie both boxing plates to each other and to the frame.

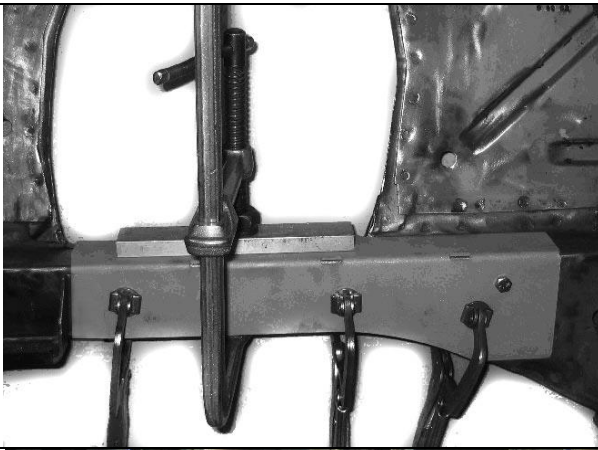

Clamping the boxing plates using support plates. Double check to make sure both plates are flat on the frame rail and as close to 90 degrees as possible to each other.

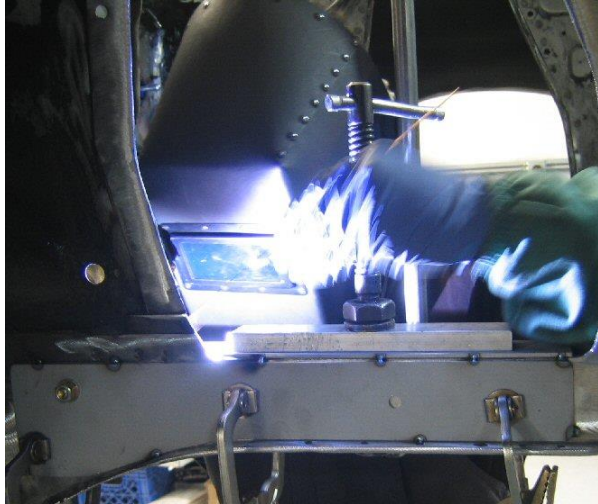

It's time to tack weld inner and outer boxing plates to each other and to the frame. When it comes to welding, I prefer to heli-arc because it's cleaner and less grinding afterwards but a wire feed will work fine, just a little more clean-up grinding afterwards.



There are rosette welds required on each boxing plate to help tie it to the frame.



Weld the outside boxing plate totally 360 degrees around tying it to the frame and the inside boxing plate.



Weld the inside boxing plate on the top, sides, and rosettes.

The portion following the bottom line of the frame will be welded later.

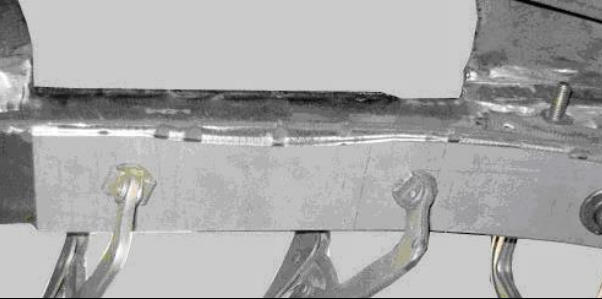

It is time to install the formed bottom boxing plate. Install it with the straight edge facing inward towards the engine compartment and the curved and notched edge facing out towards the wheel well.

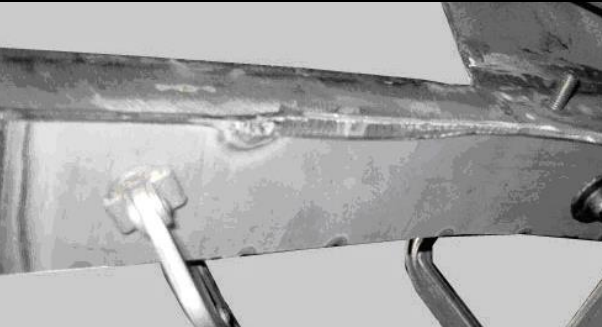

Align the inside edge of the bottom of the boxing plate parallel with the edge of the inside boxing plate allowing 1/8" gap for weld penetration.

Clamp securely checking for flatness.

Tack-weld the lower boxing plate and double check that everything is square. Weld the inside edge to frame and inside boxing plate tying both together. Weld the boxing plate on the underside of the frame. Don't weld the outside edge at this time.



The outside edge of the frame is where the two stamped flanges of the frame are spot welded together and will require clearance grinding for the coil spring before welding.



Using the outer edge of the lower boxing plate as the template, grind the two stock frame flanges till they match the profile of the boxing plate edge.

Turn the heat up on your welder and seam weld both frame flanges and the boxing plate together.

Grind and sand the weld edges, round the corners and spot weld any pits or imperfections for a clean finish.



Drill the frame through the existing 3/8" hole in the boxing plates to make the locating point for the cross member.



You are now ready to install the cross member. First install the one inch wide locating plate using a 3/8" bolt through the hole drilled earlier. Slide the cross member with the rack & pinion brackets up against the locating plate.

NOTE Driver's side pictured

You may have to trim the cross member to fit in between the rails. Trim both sides equally.

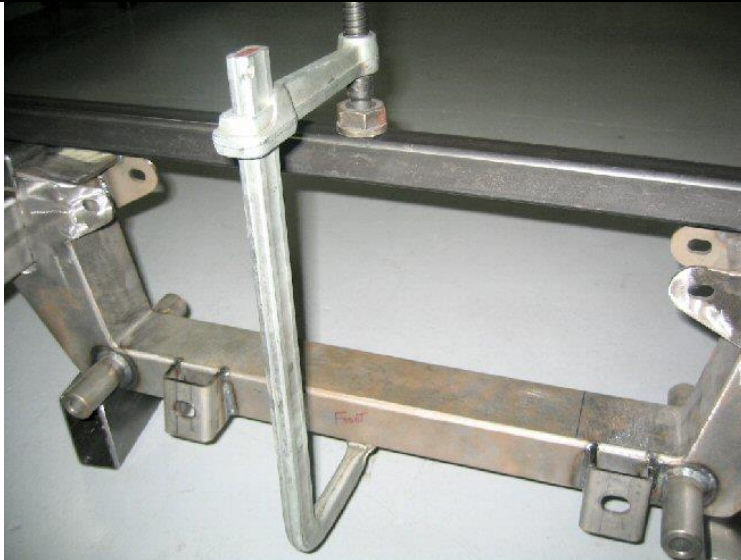

Use a sturdy flat cross bar (approximately 32" long) and a long c-clamp to pull the cross member up tight against the bottom of the frame and snug it up against the locating plates.



Check to make sure that the cross member is 90 degrees to the top of the frame. This is critical for correct engine angle and lower A-arm angle.

Corrections can be made by slightly trimming the front or rear edge of the cross member that contacts the bottom of the frame.



Double check for square and tack weld all sides and on the bottom.

Remove the locating plate and finishing welding all the way around, switching from side to side so as to not build up to much heat. Weld up the 3/8" holes on the inside and outside of the frame rails and grind flat for a clean appearance.

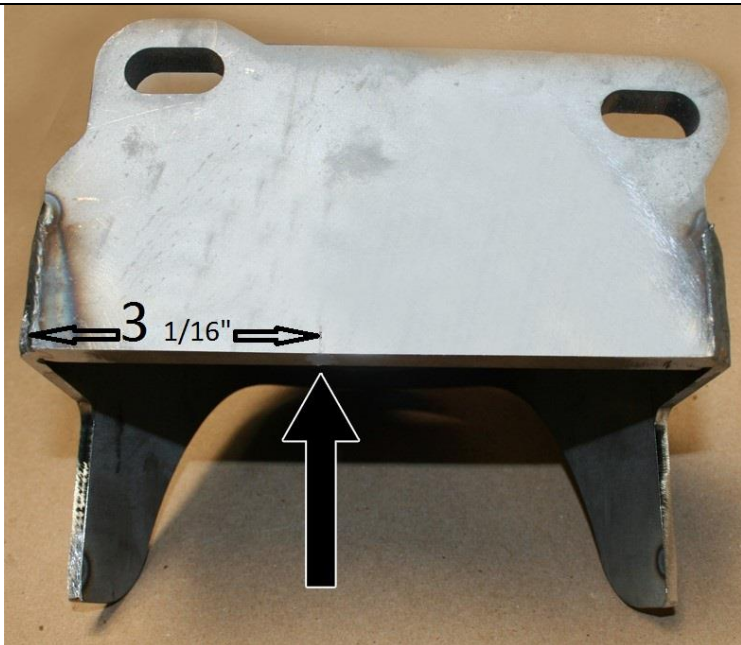

The control arm shock/coil spring tower bracket is mounted with the tall end towards the front of the car. This is the built in anti-dive feature. Set the control arm shock/coil spring tower in place with the front face 3 1/16" from the front face of the cross member.

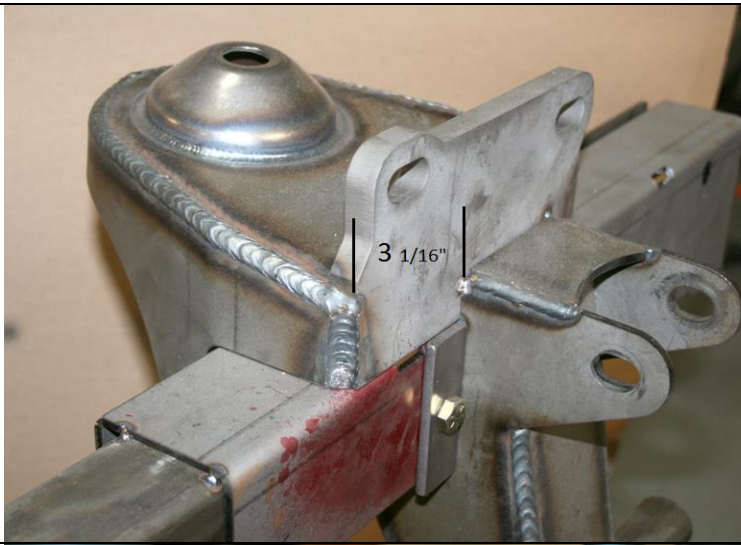

Using a C-clamp pull the bracket down snug to the top of the frame rail keeping the locating slot aligned with the front edge of the cross member and the outside legs of the bracket snug against the outside of frame rail. The mounting plate for the upper control arm should be vertical +/- .5 degrees.

When everything is tight, tack weld in several locations to prevent the bracket from moving. Double check the 3 1/16" measurement then finish welding the tower in place.



Installing the upper control arms:

Use three of the provided .090" thick washers between the tower and the control arm shaft on each bolt. The rest can be placed under the head of each bolt and under the lock nut. These spacers may need to be moved around when final alignment is performed. Once all the hardware is in place go ahead and set the bolts in the center of alignment slots and tighten down.

The slotted arm mount holes will make it easy to add in extra positive caster for power rack applications

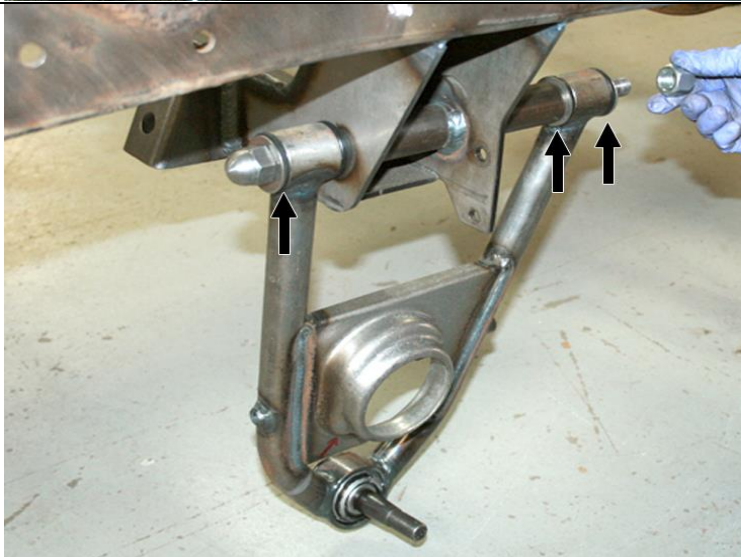

Installing the lower control arms:

The lower a-arms are installed with the sway bar bung facing forward and ball joint threaded stud facing up. The 5/8" pivot shaft is installed with the acorn nut facing forward with a thin stainless washer being used where the arrows show. Lightly tap the shaft into place making sure a washer is installed in the proper location.

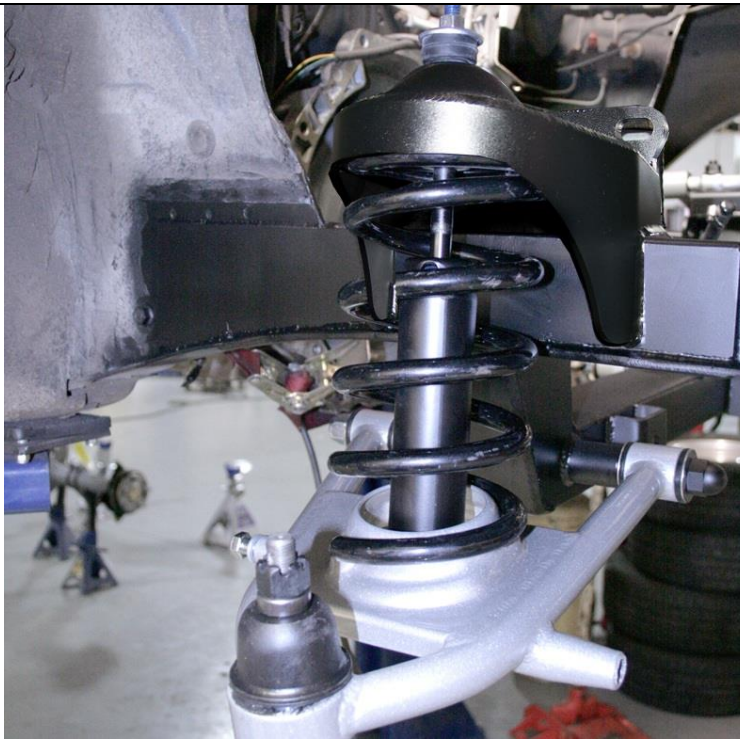

We suggest that you wait until final vehicle assembly (vehicle at full weight) to install the coil springs because it will put undue stress on the ball joints and could cause the boots to tear. Another option is to remove the upper and lower ball joint boots and then cover the ball joints to keep dirt out until you're ready to drive the vehicle.

The coil spring and shock are next.

This is a two person task. Have a jack ready to put under the ball joint end of the a-arm after spring is seated. Remove the zerk fitting in the ball joint as to not damage it during this process.

Install the coil spring with the flat ground end going up into the coil spring tower and the pig tail end of the spring facing down and indexed into the a-arm spring pocket. The spring will have to be compressed in order to install the shock.

For Proper Installation of Coil Springs A Spring Compressor is needed

Here are some helpful hints for installing the springs without a spring compressor.

Installing the coil springs onto the front end

Before you Start:

***NOTE* It is best to use a spring compressor for this process. If you do not have a spring compressor this is an effective way to install your coil springs**

Additional Components Needed:

Very strong ratcheting tie downs with hooks
Floor Jacks
Clean Towel

1. **(Image A)** With the vehicle securely positioned on jack stands remove the grease fitting on the lower ball joint. Install the coil spring with the flat ground side up in the spring pocket and the pig tail end inserted onto the notched portion on the lower a-arm. Use a long screwdriver or flat bar inserted above the last coil and hooked through the coil pocket to hold the spring from coming out as you jack up the a-arm.
2. **(Image B)** Position the floor jack under the lower a-arm as shown with a clean towel protecting the finish.
3. **(Image C)** Hook the ratcheting tie down to the front of the floor jack cross bar, then go up and over the upper a-arm mounting bracket. With the other end of the tie down hooked to the other side of the jack's crossbar. This keeps the frame from going up as you raise the a-arm.
4. **(Image D)** Slowly raise the jack until it is safe to remove the large screwdriver holding the spring in place. Keep raising the jack until the lower a-arm is high enough to fit the shock absorber into place.

Coil Spring Installation

Helpful Hints For Installing Springs

We suggest that you wait until final vehicle assembly (vehicle at full weight) to install the coil springs because it will put undue stress on the ball joints and could cause the boots to tear. Another option is to remove the upper and lower ball joint boots and then cover the ball joints to keep dirt out until you're ready to drive the vehicle.

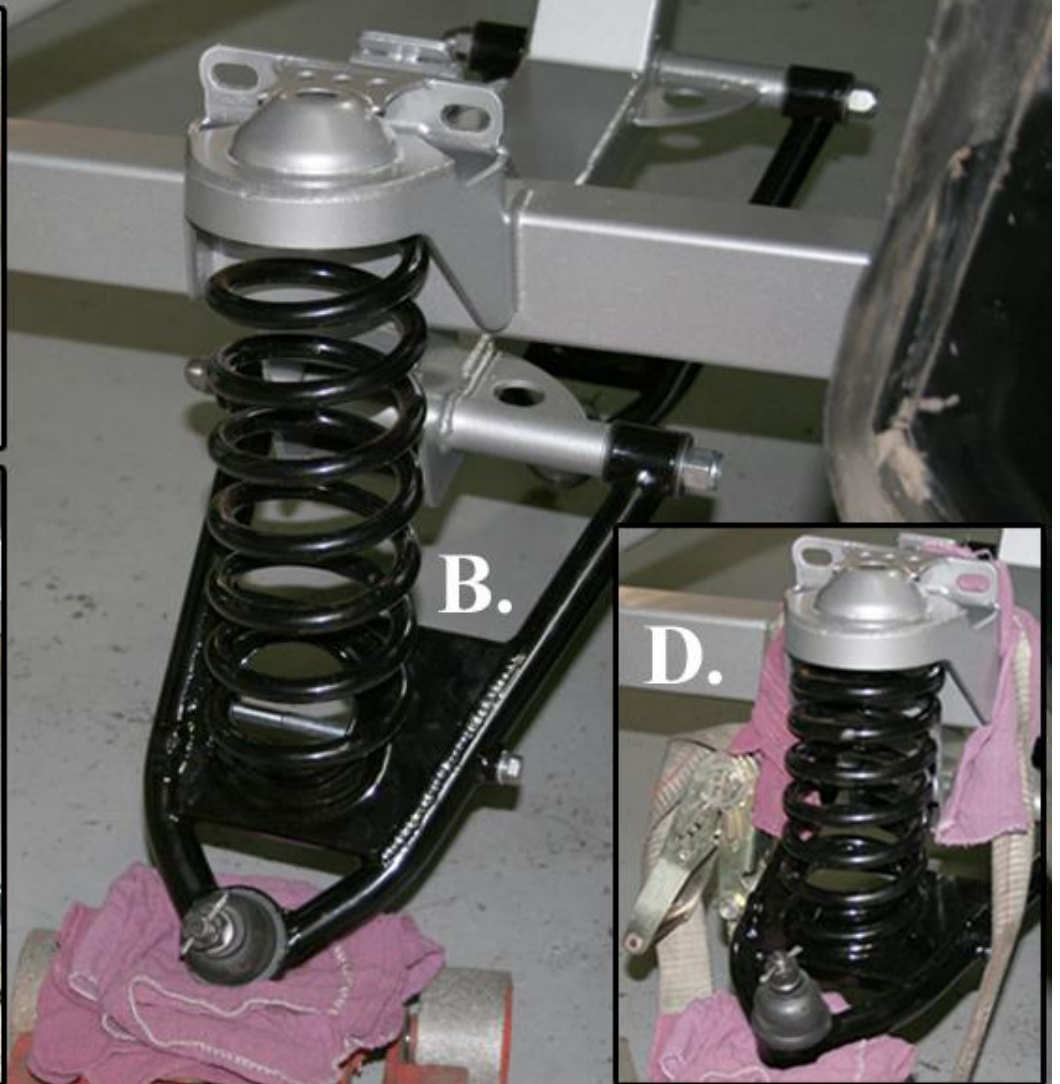
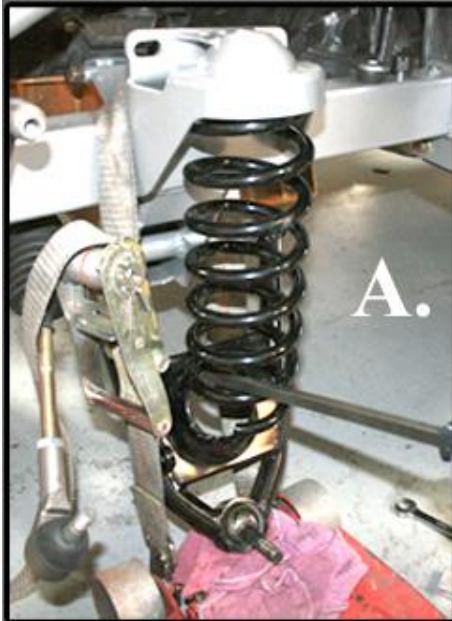
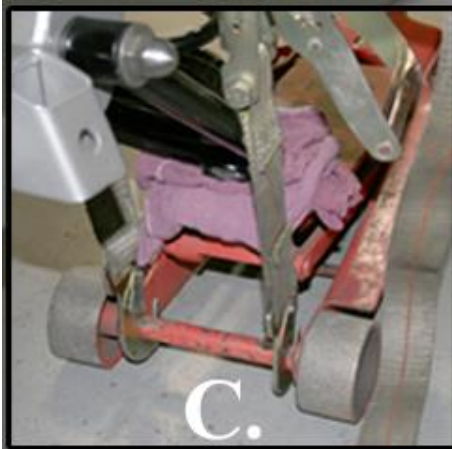

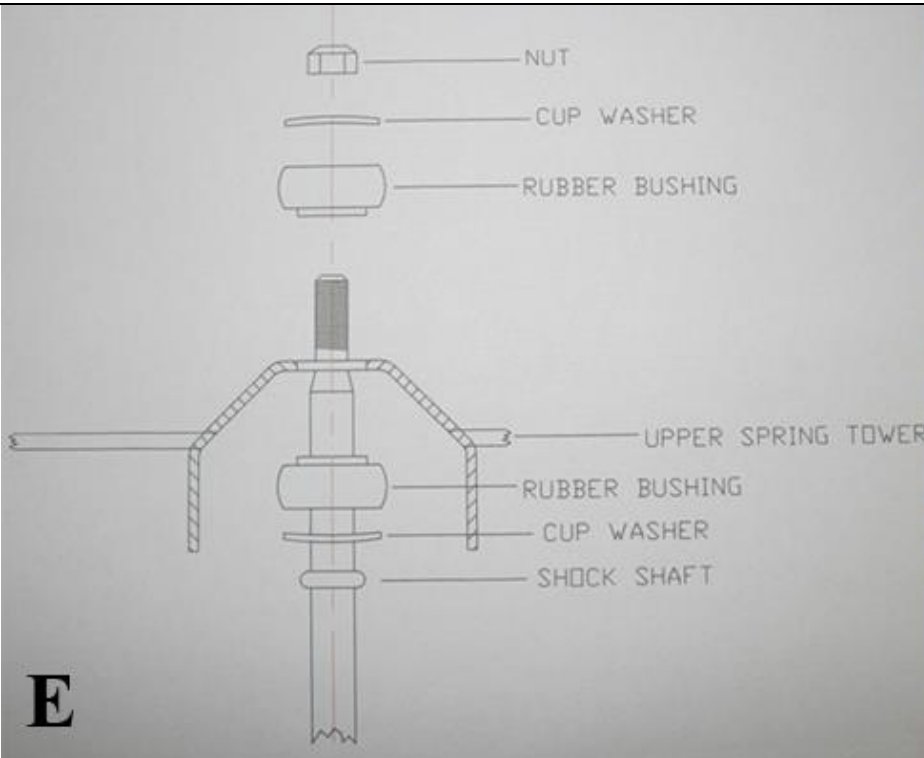

E

F

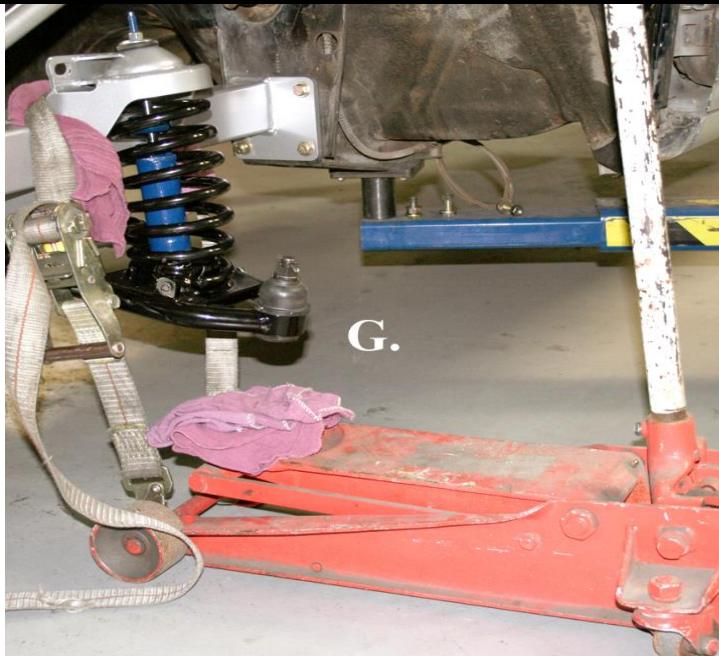

G.

5. **(Image F)** Install the shock through the bottom of the lower a-arm with the shock stem going through the mounting hole in the upper hat. Align the lower shock sleeve with the shock bosses on the lower a-arm and install the 7/16" shock bolt and tighten

Note: If you have difficulty with the sleeve fitting between the bosses lightly sand the ends of the sleeve.

6. **(Image E)** Install the cup washers, bushings and nut on top of the shock stem and tighten. Carefully lower the jack and remove the ratchet tie down. Re-install your ball joint grease fittings. **(Image G)** This is what your installed spring will look like.



****Addendum****
Ridetech Coil-Over upgrade

Turn the adjustment ring on the shock as far down as possible.

Install the spring onto the shock with the small tapered side of the spring down against the flat rubber insulator and adjuster ring.

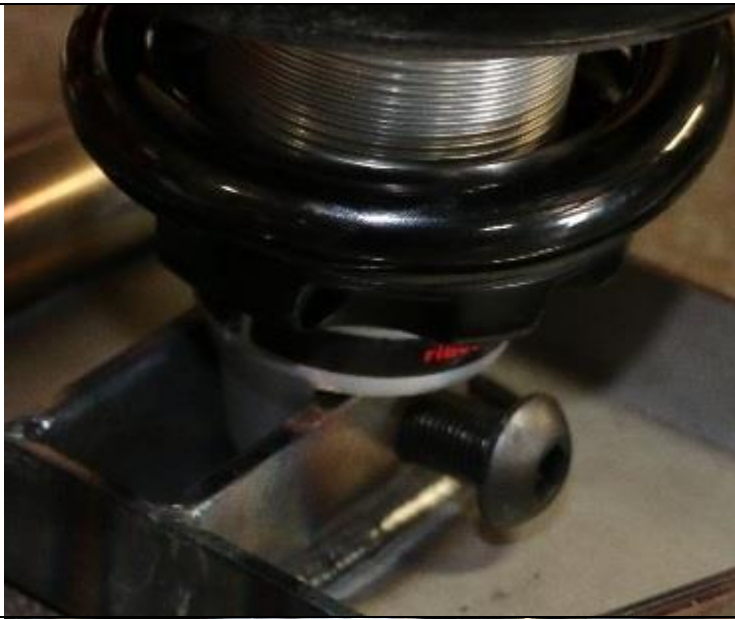

Place the shock onto the lower control arm and install the provided 1/2" button head bolt.



Install the nylock on the opposite side and tighten down.



Use a T10 Torx head to remove the screw at the top of the shock/adjuster knob.



Remove the adjuster knob and screw and set it aside for now.



Remove the nylock, thick washer and concave insulator and set them aside for now.

NOTE There are two halves of the concave insulator, leave the bottom half installed on the shock.



You can now lift the lower control arm and shock/spring combo up into the upper hat assembly. Align the shock shaft into the center hole of the upper hat.

This is where making sure the adjuster ring was all the way down or not will make all the difference. If it wasn't the stud will not protrude far enough to reinstall the top end of the shock.

NOTE Make sure the shock shaft is fully extended



Reinstall the concave insulator and thick washer on top of the upper hat assembly



Reinstall the nylock and tighten it down



Using the same T10 Torx you can now reinstall the adjuster knob and screw



Installing the spindle assemblies:

Place the spindle onto the lower ball joint with the steering arm facing forward with the large I/D tie rod end taper facing down. (The tie rod end goes up into the spindle)

Place the ball joint washer first and then the castle nut. Torque the lower ball joint to 90 ft. lbs and install the cotter pin. The lower ball joint is a **MOOG K719**



Pull the upper control arm down onto the spindle. Place the ball joint washer first and then the castle nut. Torque the upper ball joint to 70 ft. lbs and install the cotter pin. The upper ball joint is a **MOOG K772**

NOTE Caliper Fittings:

GM Calipers = 10mm x 1.5

Wilwood Calipers = 1/8" NPT

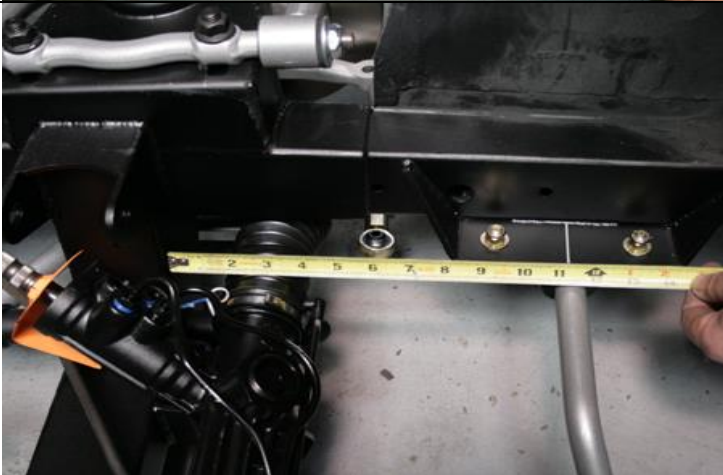

The sway bar bracket is mounted 11.25 inches from the front edge of the cross member to the center of the bracket.

Clamp securely to the bottom of the frame with the wings flush against the inside of the frame and weld them in place.



Install the rack & pinion

Install the rack and pinion gear assembly using the two 5/8 inch bolts with anti-seize on the threads and tighten.

Note. Some rack bolt kits come with two 5/8 inch thick spacers. They are not to be used on this application. The rack bushings set directly against the brackets on the cross member using no spacers.

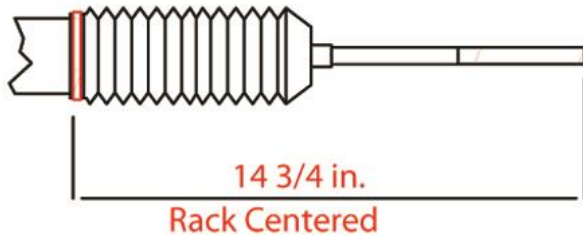
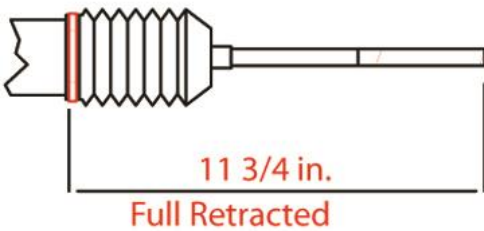
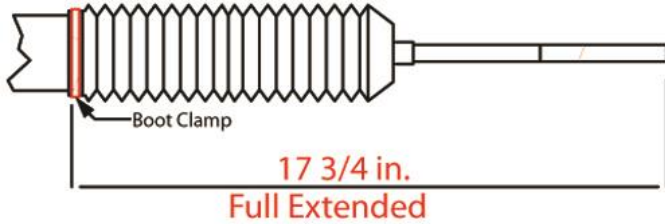

The rack assembly needs to be centered to allow equal steering left to right. On a bench, turn the pinion out to lock one way. Measure from a convenient point to the end of the tie rod. (This rack was $17 \frac{3}{4}$). Turn the pinion to the opposite lock position and measure from the same point to the end of the same tie rod ($11 \frac{3}{4}$). $17 \frac{3}{4}$ minus $11 \frac{3}{4}$ = 6. Divide by 2=3 Add that number to the smallest measurement ($11 \frac{3}{4}$ + 3" = $14 \frac{3}{4}$ ") and turn the pinion back till you get that measurement and your rack is centered.

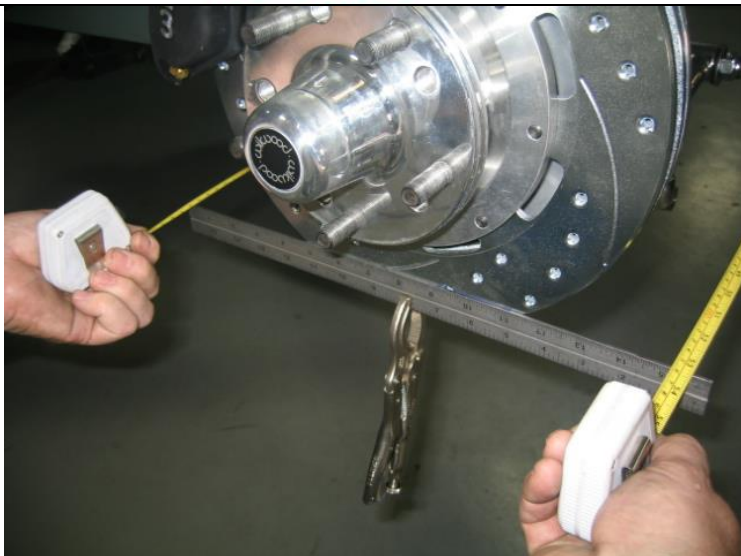

Before installing the tie rod ends onto the rack assembly, align the rotors straight forward and clamp a straight edge to each rotor as shown then using a tape measure side to side; set the toe-in approximately 1/8" for a starting point. Adjust the tie rods onto the rack assembly evenly to keep the rack centered for equal turning left and right.

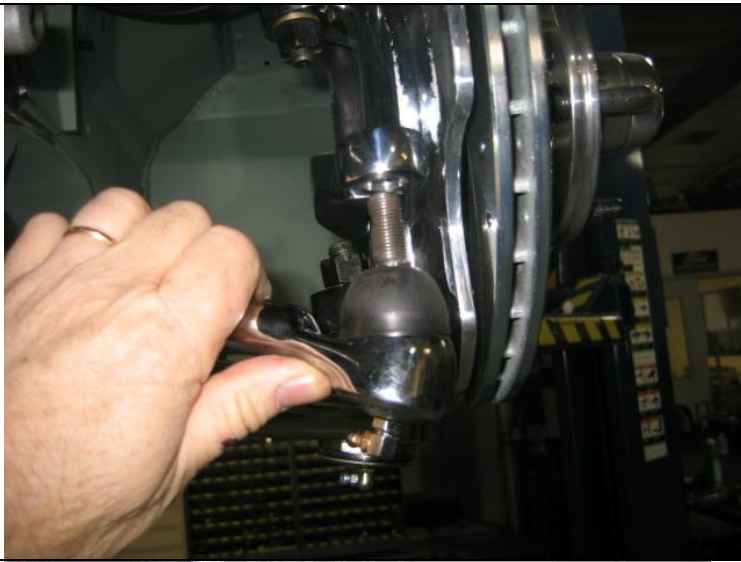

Install the tie rod end jam nut and then the tie rod end turning it an equal amount of turns per side until they line up with the steering arm tapered hole. Check the toe-in again, adjust if needed.



Install the anti-sway bar (center drop of bar down) using the four 3/8" bolts, washers and nylock nuts. The spacer plate goes against the frame bracket first then the saddle bracket next. The brackets are slotted to allow adjustment when aligning the rod end links from the sway bar to the lower a-arm. Cycle the bar up to check for interference with the flange on the edge of the frame, trim frame flange if needed. The rod end links are installed male end down using the 1/2 inch button head bolts. Definitely use anti-seize on the threads because the rod ends see a lot of water.

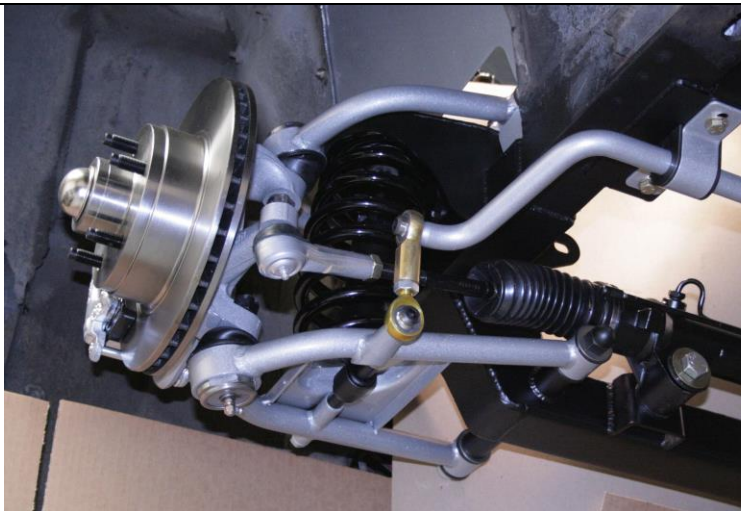

The finished assembly.

The steering column and linkage will be next.



The stock steering column can be cut and modified to work but I chose an Ididit brushed steel two inch diameter tilt retro fit steering column (TCI # 326-3100-00) and a Borgeson steering linkage package (TCI # 310-3120-03) to connect the rack and pinion to the steering wheel.



Setting up power steering

The rack ports are 9/16"-18 Pressure side & 5/8"-18 Return side
Unisteer 8026070 is a recommended fitting kit.

The recommended pump output is 800-1000psi and 2.0 gallons per minute. Exceeding this can cause the steering to feel "twitchy" and excess pressure can damage the rack.

The steering u-joint is 9/16 x 26 spline for the manual rack.

The power rack is 3/4 x 36 through April '21. After April '21 it is 3/4" Ford V.

The Sweet Mfg. 401-51927 u-joint is recommended for the power rack due to the tight space.

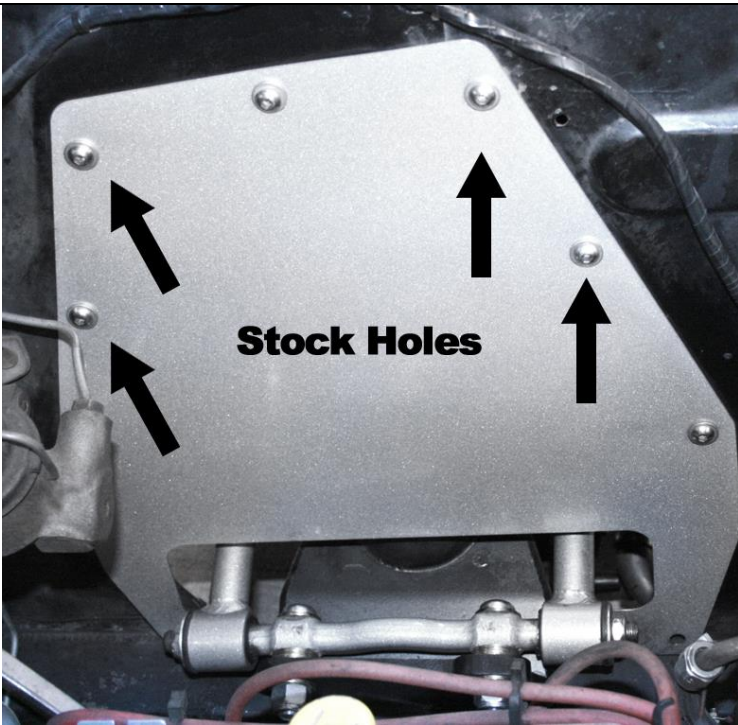

The inner fender panels are installed using the 4 existing holes that the factory bump stop bracket bolted on to the rest will have to be drilled out. Using a 5/16 inch bit, drill the remaining holes in the inner fender panel and install the 5/16 inch button head bolts, washers and Nylock nuts.

Alignment specifications

Caster: Power rack 4-6 degrees positive

Manual rack 2-4 degrees positive

Camber: 0 Degree

Toe-in: 1/32 to 1/16 inch

After 500-1000 miles the front springs will begin to break in. The lower control arms should be level to the ground or within a degree or two. You can now perform the final alignment. If the vehicle is still too high after 1000 miles it may be necessary to cut some of the coil off. Never cut more than a 1/4 coil off at a time.

AXLE STUD SIZES:

4.5" Bolt circle rotors = 1/2"x20 ('75-80 Ford Granada)

4.75" Bolt circle 10.5" rotors = 12mmx1.5 ('82-87 Camaro)

4.75" Bolt circle 11" rotors = 7/16"x20 ('75-80 Granada redrilled)

ALL Wilwood hubs = 1/2"x20



OIL PANS

289-302 = Ford Racing # M-6675-A50

351 Windsor = Ford Racing # M-6675-A58

429-460 = Ford Racing # M-6675-A460

No returns or exchanges without a RMA#.

Packages must be inspected upon receipt & be reported within 10 days.

If you are missing parts from your kit, TCI Engineering will send the missing parts via FedEx or U.S. mail ground.

Returned packages are subject to inspection before replacement/refund is given. (Some items will be subject to a 15% restocking fee)

Thank you for your business!

