

# Save 10% *Best Deal!*

+ \$500 towards chassis upgrades

Unmatched Warranty. Fastest Lead Time!



## 1937-1959 CHEVY TRUCK

### 5-PIECE TOTAL PACKAGE

#### '47-59 CHEVY TRUCK

1. Custom IFS
  2. 4-Link Rear Suspension
  3. Power Pedal Assembly
  4. Engine Mounts
  5. Trans Mount
- + Ridetech Coil-Over Option Included

SHOP NOW

**\$299**  
FLAT-FEE  
SHIPPING

Retail: \$7,529

Save: **\$753**

Your Price: **\$6,776**



Painting & powder coating for display only

#### '37-59 CHEVY TRUCK

1. Coil-Spring IFS
2. Parabolic Leaf Spring Rear Suspension
3. Power Pedal Assembly
4. Engine Mounts
5. Trans Mount

SHOP NOW

**\$299**  
FLAT-FEE  
SHIPPING

Retail: \$4,832

Save: **\$483**

Your Price: **\$4,349**



Painting & powder coating for display only

#### '55-59 PRO-TOURING IFS

- Custom spindles and steering allow us to control every portion of suspension geometry
- The upper control arm mounting brackets provides easy alignment, tuning adjustability and control of camber and caster

SHOP NOW

Retail: \$4,897

Save: **\$490**

Your Price: **\$4,407**



**\$299**  
FLAT-FEE  
SHIPPING

Save 10% Off Plus \$500 towards chassis upgrades

#### '55-59 GROUNDED CHASSIS

- 1" off the ground with 26" (front) & 28" (rear) tall tires. Main rails with an extended height from 6" to 8" for increased rigidity. The center section is custom built for each chassis to match the customer specified engine and transmission.

SHOP NOW

Retail: \$18,375

Save: **\$1,837**

Your Price: **\$16,538**

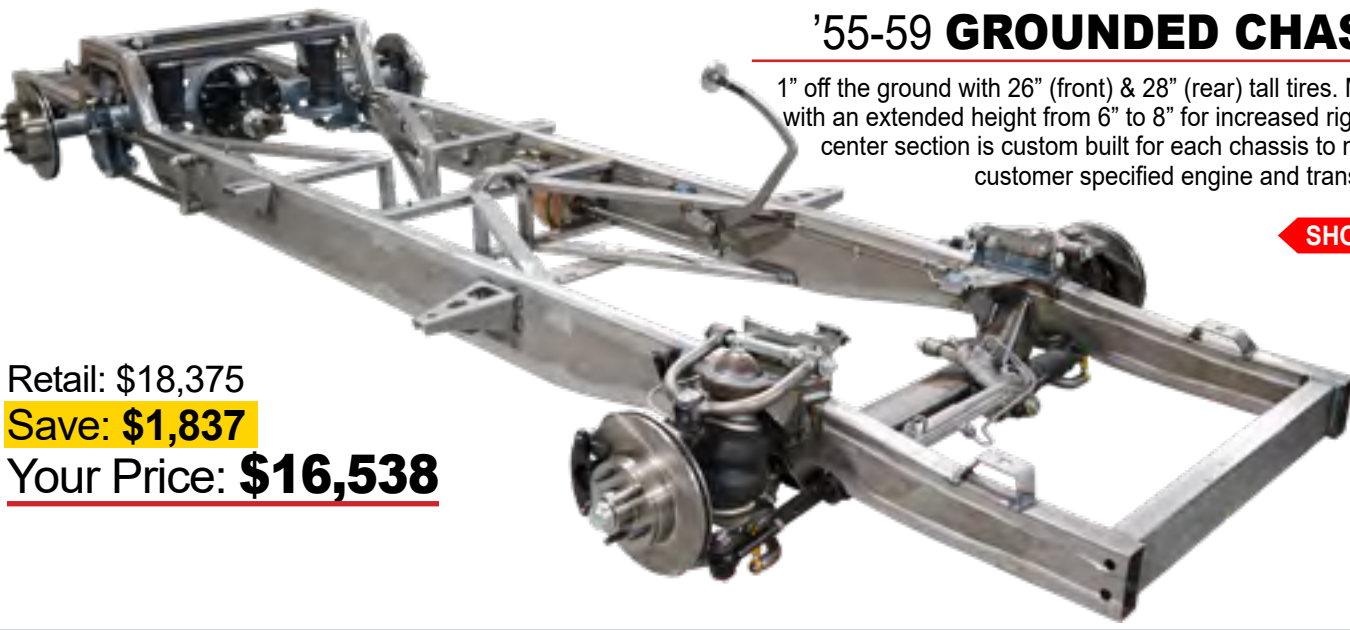

#### '55-59 PRO-TOURING CHASSIS

- 8" tall main frame rails that follow the original frame profile.
- Performance Pro-Touring IFS and Torque Arm Rear Suspension.

SHOP NOW

Retail: \$18,401

Save: **\$1,840**

Your Price: **\$16,561**



#### '47-54 GROUNDED CHASSIS

- Stepped rail design provides enough wheel travel to lay the running boards on the ground
- Fully plumbed air bag set up provides ultimate control of ride height

SHOP NOW

Retail: \$18,375

Save: **\$1,838**

Your Price: **\$16,537**



Painting & powder coating for display only



#### '54 & '55 (1st SERIES) CUSTOM IFS & 4-LINK CHASSIS

- The frame features main rails with an extended height from 6" to 8" for increased rigidity and clearance between upper and lower x-members while still retaining the original profile

Retail: \$16,615

Save: **\$1,662**

Your Price: **\$14,953**



#### '47-59 CUSTOM IFS & 4-LINK CHASSIS

- 8" Tall fully boxed frame rails offer exceptional strength and rigidity
- Lowered stance and center of gravity provide superior handling

SHOP NOW

Retail: \$16,615

Save: **\$1,662**

Your Price: **\$14,953**



Shown with optional show package, Wilwood 12" brake kit and F9 housing.

Painting & powder coating for display only



#### '47-59 COIL SPRING IFS & LEAF SPRING CHASSIS

- Custom built center section offers strength while still allowing exhaust clearance
- Parabolic Leaf springs offer greater flexibility which promotes ride quality

SHOP NOW

Retail: \$15,325

Save: **\$1,532**

Your Price: **\$13,793**



½ ton trucks. Painting & powder coating for display only



• DUAL WARRANTY •  
LIFETIME WARRANTY ON TCI MANUFACTURED ITEMS  
6 YEAR/60,000 MILE WARRANTY ON WEAR & TEAR ITEMS



FAST SHIPPING  
MADE IN USA • UNMATCHED WARRANTY

CALL NOW! **1.866.925.1103** • **TOTALCOSTINVOLVED.COM**